



HamTV Experiment on-board ISS

HamTV – An Amsat-Italia proposal and preliminary tests for a DVB-S Amateur TV transmission from the International Space Station.

F. Azzarello IW8QKU, E. D'Andria IØELE, T. Giagnacovo IZ8YRR, P. Tognolatti IØKPT

Corresponding author: Fabio Azzarello, email: iw8qku@amsat.org

Abstract

Scope of this paper is to present an experiment of digital video transmission from the International Space Station. It could be a challenging experiment for amateurs interested in television tests and a complement of the half-duplex voice link carried out within the ARISS school contacts activities.

The paper will start with the process of identification of the most suitable frequency band and of the standard technology for a video transmission (Analog or Digital) and will proceed with the identification of the most suitable commercial off-the-shelf (COTS) hardware as a solution for the implementation of the payload.

First lab experiments results will be also presented as well as an architecture of the receiving earth station.

The payload is intended to be embarked on the Columbus module of the ISS where an amateur station will be installed and operated. It will use the VHF/UHF and S-Band antennas already placed outside the European module.

Introduction

The installation of S-band equipment in Columbus module will open a new era for Amateurs as well for ARISS School Contacts.

In combination with VHF audio the HAMTV downlink will provide schools and amateurs, all over the world, a real time view inside the ISS.

A television beacon mode will be also foreseen to allow amateurs to experiment with different downlink configurations.

The sequence of voice and video sent down to the earth will be captivating, procuring a very intense experience of the pass of the ISS over the ground station.

For direct contacts, the equipment will be more complex than for audio contacts: an S-band receiver will be needed with an appropriate directive antenna as well as the complete HAMTV equipment.

Frequency Band Selection

A preliminary investigation of the UHF, L and S Bands allocated to the radio amateur service, aiming at selecting the proper frequency band for the HAMTV experiment from the International Space Station, has identified the S-Band to be the best candidate for the HAMTV Experiment.

This band can handle both digital and analogue television, because of the necessary bandwidth for the transmission of a television signal, and it can guarantee enough link margin by using high-gain antenna.

On the other hand, S-Band is heavily used on-board the ISS: bands are allocated to the Space Operations Service (i.e. 2025-2100 MHz ↑ and 2200-2290 MHz ↓) and, in addition, there is a Wi-Fi activity on-board in the frequency band 2400-2483.5 MHz which overlaps with the HAMTV frequencies (2400-2450 MHz).

However, the S-Band could be compatible with the Space Operation Service of the ISS if an appropriate filtering of the receiver and of the HAMTV transmitter is present, this need to be proved.

It has to be noted that Wi-Fi terminals are able to operate in an interfering environment (ISM Bands) but in order to minimize the potential interference it is suggested to adopt an HAMTV modulation scheme which requires less power and less bandwidth.

In addition a shielding effect could be considered due to the fact that the HAMTV transmitter will radiate outside the Columbus module while the Wi-Fi networks are intended to be used inside the ISS, this should improve their electromagnetic compatibility. A further improvement can be obtained with a careful selection of the HAMTV frequency carrier (i.e. channel 3 at 2.422 GHz) in a empty portion of the spectrum.

Since the S-Band is really crowded a possible solution is to propose a modification of the IARU Band Plan to allow amateur satellite applications outside the ISM frequency bands.

Analog or Digital

To evaluate the best technology to use, in order to make contacts more reliable, a number of different approach was faced. Link budget calculations were done for both analog and digital systems [REF1,2] over the three band of interest.

As first selection the L band was abandoned, even if it was the most promising, because of regulatory constraints (L band cannot be used for any space downlink).

Operating frequency	435-438 MHz		1260-1270 MHz		2400-2450 MHz	
	ANALOG FM	DIGITAL DVB-S	ANALOG FM	DIGITAL DVB-S	ANALOG FM	DIGITAL DVB-S
Modulation type	ANALOG FM	DIGITAL DVB-S	ANALOG FM	DIGITAL DVB-S	ANALOG FM	DIGITAL DVB-S
Link budgets assumptions (antenna gains, losses, intermodulation, etc)	N.A. Band limitation	QPSK FEC ½ FEC 7/8	N.A. Downlink restrictions	N.A. Downlink restrictions	FM 16 MHz-pp	QPSK FEC ½
On board RF output power (with estimated back-off, efficiency and resulting DC power consumption)	N.A.	10 W	N.A.	N.A.	10 W	10 W
Instantaneous bandwidth	-	2.93 MHz 1.67 MHz	-	-	28 MHz	1.35 MHz
Link Budget Margin	-	+13.8 dB +11.9 dB	-	-	-10.4 dB	+6.9 dB

Table 1 – Technology summary

Table 1 shows the last selected parameters [REF 3], a preliminary detailed link budget will follow. The choice was almost driven to the S band because of the quite good availability of COTS hardware at low cost. The 70 centimetres band was also abandoned because of strong interference from ground based services in Italy, COTS were also not so easy to find like for S-Band.

Link Budget Details

In this section link budget for the HAMTV system is presented. The following Table 2 shows the most important parameters/values involved in the radiofrequency link-budget as a comparison between the two standards.

DVB-S - ArCOL LINK BUDGET			FM ATV - ArCOL LINK BUDGET		
	Value	Unit		Value	Unit
Downlink frequency	2.450	GHz	Downlink frequency	2.450	GHz
Boltzmann's constant	-228.60	dBW/K-Hz	Boltzmann's constant	-228.60	dBW/K-Hz
ISS to E/S range	1000	Km	ISS to E/S range	1000	Km
EARTH STATION CHARACTERISTICS					
Antenna diameter	0.90	meters	Antenna diameter	0.90	meters
Efficiency	50%		Efficiency	50%	
Rx Antenna gain	24.3	dBi	Rx Antenna gain	24.3	dBi
Antenna Noise Temperature (¹)	100	K	Antenna Noise Temperature (¹)	100	K
Implementation losses	0.0	dB	Implementation losses	0.0	dB
Implementation equiv noise temp	0.0	K	Implementation equiv noise temp	0.0	K
Antenna pointing losses	0.0	dB	Antenna pointing losses	0.0	dB
Antenna pointing losses equiv noise temp	0.0	K	Antenna pointing losses equiv noise temp	0.0	K
LNB gain	35	dB	LNB gain	35	dB
LNB noise figure	0.8	dB	LNB noise figure	0.8	dB
LNB equiv noise temp	58.7	K	LNB equiv noise temp	58.7	K
FIGURE of MERIT G/T					
System Noise Temp	158.7	K	System Noise Temp	158.7	K
System Noise Figure	1.9	dB	System Noise Figure	1.9	dB
G/T	2.3	dB/K	G/T	2.3	dB/K

¹ Antenna noise temperature DO NOT include noise contributions from interfering systems close to the receiving station (e.g. WiFi access point, microwave ovens, video senders, radio links, etc.). A preliminary measurement of G/T is strongly recommended. Sun-noise measurement at sunrise or sunset should be a convenient method to test RX station figure-of-merit at low elevations.

CARRIER CHARACTERISTICS					
Data Rate	922	kbps	Peak to Peak frequency deviation ΔF_{pp}	16	MHz
Reed Solomon	188/204		TV signal bandwidth B_v	6	MHz
Modulation	QPSK		Modulation	FM	
FEC	1/2		Carrier's occupied bandwidth	28	MHz
Symbol Rate	1000	kbaud	p_w [Unified] CCIRR Rep. 637 pre/de-emphasis gain ²	13.2	dB
Mod. Factor (2=QPSK, 3=8PSK, ..)	2				
Brutto BitRate	2000	kbps			
Roll-off (%)	0.35				
Carrier's occupied bandwidth	1.35	MHz			
DOWNLINK					
TX power	10.0	dBW	TX power	10.0	dBW
cable & connector losses	7.0	dB	cable & connector losses	7.0	dB
TX Antenna gain (boresight)	8.0	dBi	TX Antenna gain (boresight)	8.0	dBi
pointing losses	10.5	dB	pointing losses	10.5	dB
Downlink e.i.r.p. toward earth rx station	0.5	dBW	Downlink e.i.r.p. toward earth rx station	0.5	dBW
Downlink path loss (free space)	160.3	dB	Downlink path loss (free space)	160.3	dB
Atmospheric losses	0.0	dB	Atmospheric losses	0.0	dB
Noise increase due to precipitation	0.0	dB	Noise increase due to precipitation	0.0	dB
Rain attenuation losses	0.0	dB	Rain attenuation losses	0.0	dB
			C/N (Available)	-3.4	dB
C/No	71.1	dBHz	C/N (required due to demod. threshold)	7.0	dB
C/N	9.8	dB	Margin on C/N	-10.4	dB
Eb/No (Available)	11.4	dB	S/N (Required for P3 video quality)	25.0	dB
Eb/No (Required)	4.5	dB	C/N0 (available)	71.1	dBHz
Link Margin	6.9	dB	C/N0 (Required for P3 quality)	69.3	dBHz
			Margin on C/N0	1.8	dB
			Link Margin	-10.4	dB

Table 2 – Link Budget Comparison

Once we have selected the first optimized parameters for the DVB-S transmission (output power, transmission rate and so on) we have summarized the link budget calculations on the following Fig. 1, (left side). On the right panel of the same figure it is possible to evaluate the attenuation due to rain, as showed it could be considered negligible at the selected frequencies [REF 4].

² For reference see pages 8-20 in: <http://www.authorstream.com/Presentation/Gavril-30933-satcommsspring2005-Satellite-Communications-BSpring-Semester-2004-5-Broadcasting-Contents-Analogue-System-model-FDM-FM-as-Entertainment-ppt-powerpoint/> or Dennis Roddy, "Satellite Communications", 3rd Ed., McGraw-Hill, 2001.

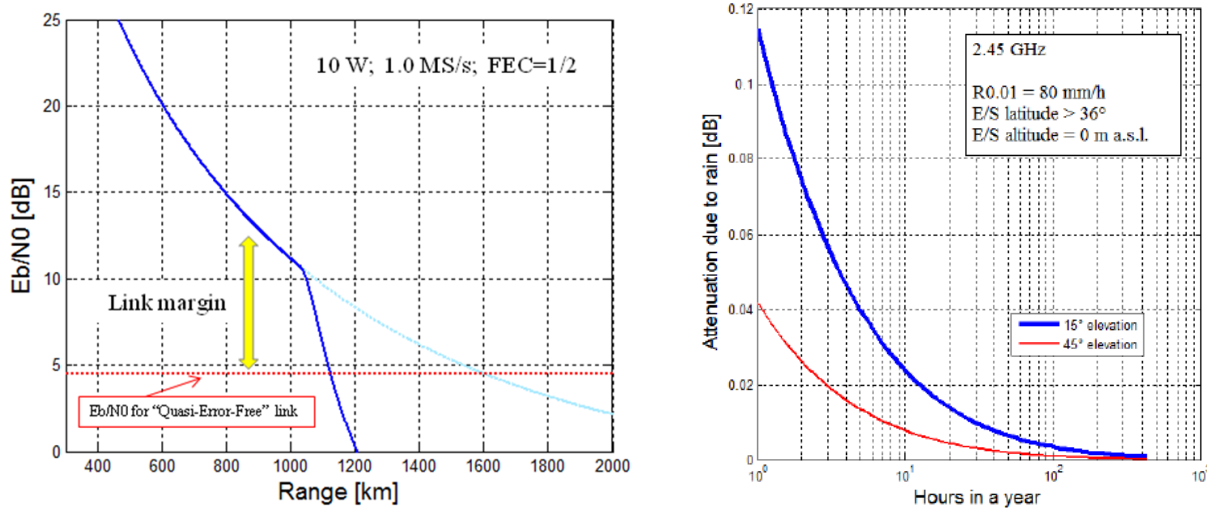

Figure 1 – Left panel: link margin vs. range, for DVB-S and system parameters as in Table 2; the dashed light-colored curve shows the behavior if the antenna temperature were 100 K for every elevation, i.e. if ground thermal noise and interferences were neglected. Right panel: rain attenuation vs. time percentage.

Payload

In this section the HamTV transmitter concept is outlined.

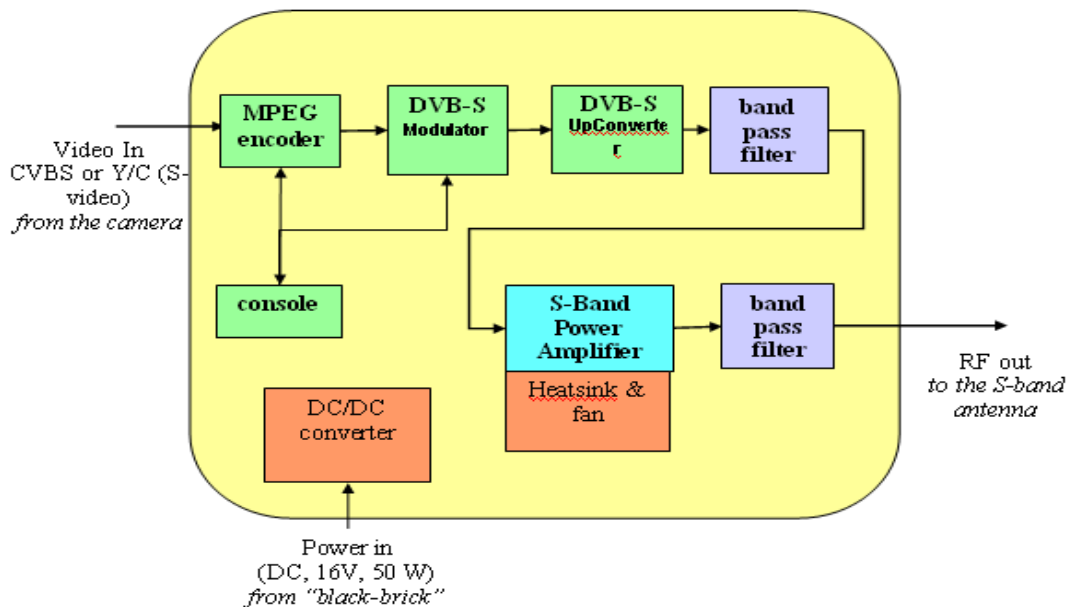

Figure 2 - HamTV transmitter block diagram

The block diagram in Figure 2 should be detailed enough: the video source could be a common camcorder that feeds the HamTV system. The encoder translates the input in a MPEG stream which will be modulated to the S-band with the selected modulation scheme and then transmitted to the Ground Stations.

The COTS components that we have selected for testing, are among the most widely used in the ham radio community, this should also guarantee a sufficient capability to use and operate such equipments.

First experiments and results

The following schematic shows the AMSAT-I laboratory setup at IZØLTG labs.

This setup is designed to assess the main performances of MPEG encoding at different FEC rates, coding parameters and to measure receiver's performances at different Signal-to-Noise ratios. All measurements were run in "IF-loop" mode, which means that the connection between TX and RX is performed at IF signal (at about 1 GHz). The spectrum analyzer shows the emission of the setup.

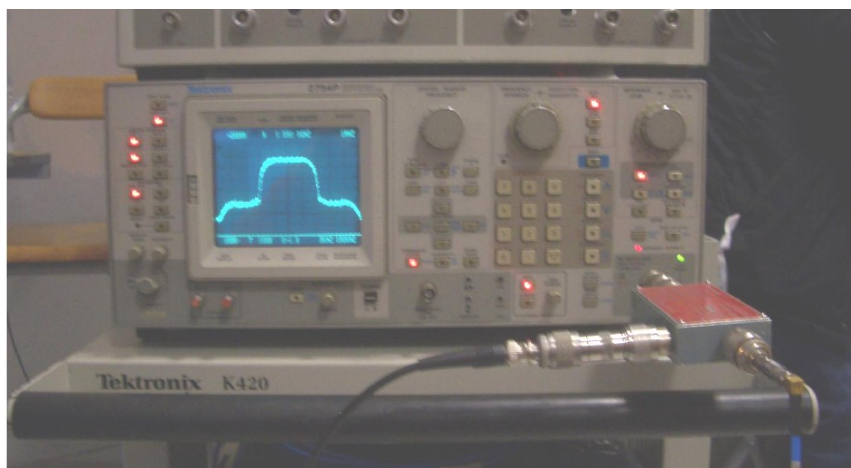
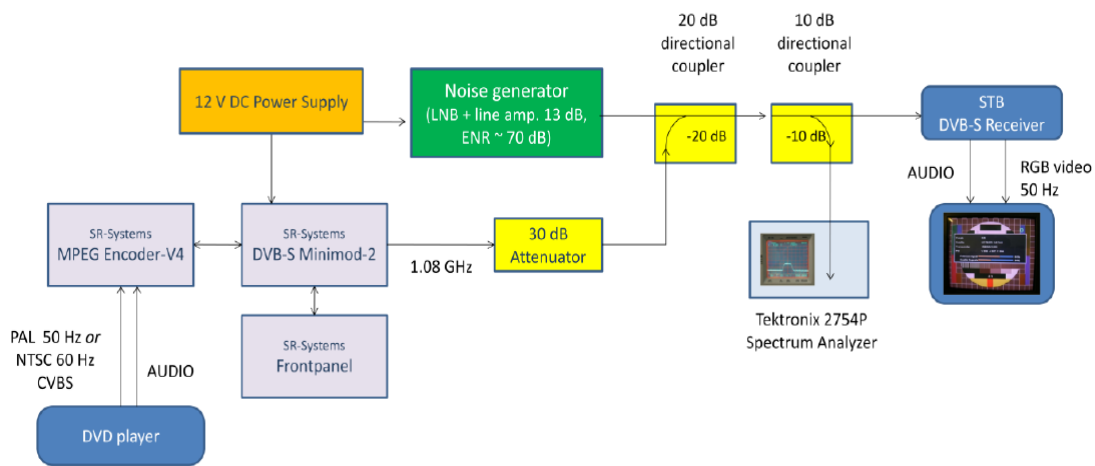

Figure 3 - Laboratory setup for IF-loop measurements on HamTV system.

Ground Station Architecture

A basic radio amateur station able to receive HamTV from ISS is proposed in the following Figure 4

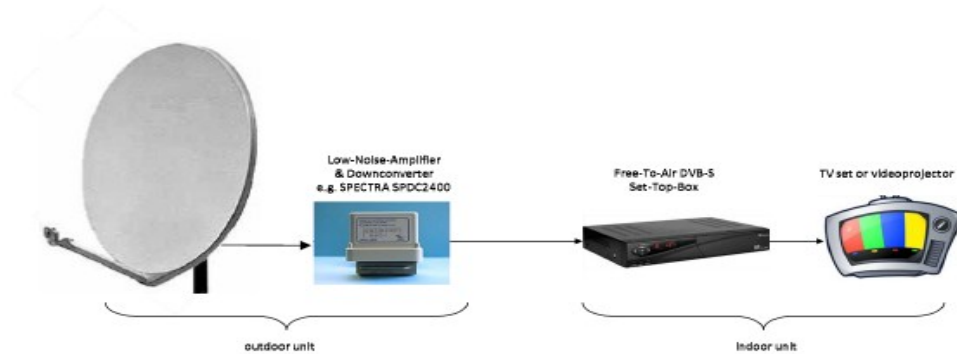

Figure 4 - Ground Station architecture

The receiving system, of course, is designed taking into account link budget calculations shown in Table 2. A 90cm dish with proper feeding should be adequate enough to reach minimum system requirements. Side lobe suppression and G/F figure optimization must be pursued. Since patch antenna on-board ISS are circularly polarized (RHCP), also ground stations must be equipped with circular polarized antenna feeds.

Conclusions

First lab tests results make us confident that the link will be reliable enough to guarantee successful contacts. Other tests are ongoing, we're trying to verify that even in marginal conditions the system will perform correctly, we are also checking the possibility to extend the link duration using multiple stations (chains).

Authors would like to acknowledge valuable discussions on HamTV with Francesco De Paolis Ik0WGF, Marco Lisi IZ0FNO, Ottorino Odoardi IZ6BMP, Paolo Pitacco IW3QBN, Pierluigi Poggi IW4BLG and with Gaston Bertels ON4WF together with the ARISS/ARCOL WG.

References

- [REF 1] - ETSI EN 300 421 V1.1.2 (1997-08) - Digital Video Broadcasting (DVB); Framing structure, channel coding and modulation for 11/12 GHz satellite services.
- [REF 2] - ETSI TR 101 290 V1.2.1 (2001-05) - Digital Video Broadcasting (DVB); Measurement guidelines for DVB systems.
- [REF 3] - Amsat-Italia Doc HamTV 002 Issue 2 - 21 April 2010
- [REF 4] - ITU-R P.618-7 - Propagation data and prediction methods required for the design of Earth-space telecommunication systems.